

Split Heat Pump For Heating & Cooling

This manual applies to the model: BLN-012TA1S



Please read carefully before installation or operation

Note:

1. Please read the instruction manual carefully before installation or operation.
2. The heat pump must be installed by a professional installer.
3. Please follow the instruction manual strictly when install the heat pump.
4. If any update on the product, this instruction manual are subject to change without notice.
5. This product must use a copper core power cord that meets the required wire diameter for independent power supply and distribution, and the system must have a reliable grounding wire; if the wiring does not meet the requirements, the system cannot work normally, the company will not be responsible for this.

Content

User Instruction.....	2
Controller Instruction	5
Dimension & Drawing.....	10
Installation.....	12
Commissioning.....	27
Maintenance & Service.....	29
Trouble Shooting.....	30
Technical Specification	33

User Instructions

1. Please use electrical leakage switch, otherwise there may be electric shock, fire, etc.

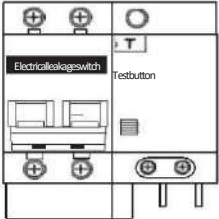

The diagram shows a control panel with two rows of terminals. The top row has two terminals with plus signs and a central terminal with a 'T' symbol. The bottom row has two terminals with plus signs and two terminals with minus signs. A label 'Electrical leakage switch' points to the top row of terminals. A 'Test button' is located to the right of the top row.

2. Make sure that the leakage protection switch is securely connected. If the wiring is not secure, it may cause electric shock, heat or fire.

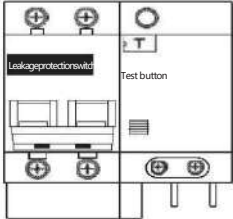

The diagram shows a control panel similar to the first one. A label 'Leakage protection switch' points to the top row of terminals. A 'Test button' is located to the right of the top row.

3. Do not operate with wet hand, otherwise there may cause electric shock

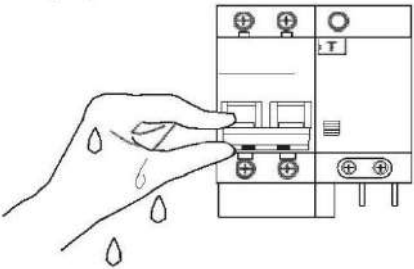

The diagram shows a hand with several water droplets on it, reaching towards the electrical control panel. The panel has terminals with plus and minus signs and a 'T' symbol.

4. Do not insert your fingers or any stick into the inside of ventilation area, otherwise harm will be caused.

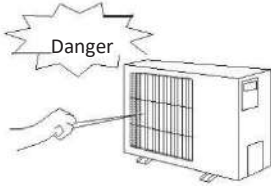



The diagram shows a hand inserting a stick into the ventilation area of a rectangular device. A starburst warning symbol with the word 'Danger' is positioned above the hand.

1. Safety Precautions

Please make sure that you have read this manual before using our air source heat pump. In the “User Information” chapter; “User Information” provides important safety information. Please be sure to follow the instructions strictly.

Symbol explanation

-  **Warning** Wrong operations are likely to cause serious consequences such as death, serious injury or major accidents
-  **Note** Improper operation may result in safety accident, damage to the machine, or affect the function of machine.

Please read the label on the machine carefully. If abnormal conditions are found during use, such as abnormal noise, smell, smoke, temperature rise, leakage, fire, etc., please cut off the power immediately and contact the company's local customer service center or dealer in time. Do not repair the system by yourself. If necessary, contact the local fire and emergency department immediately.

 **Warning**

- 1) This machine must not be installed by the user. It must be installed by an agent or a professional installation company authorized by the company, otherwise it may cause a safety accident and affect the use effect.
- 2) Except for professionals to guide the operation, non-professionals are not allowed to disassemble the machine, otherwise accidents or damage to the machine may occur.
- 3) Do not use or store combustible materials such as hairspray, paint, gasoline, alcohol, etc., around the machine, otherwise there is a possibility of fire.
- 4) The main power switch of the system should be placed out of the reach of children to prevent children from playing with the power switch and dangerous.
- 5) Do not sprinkle water or other liquids on the machine, otherwise it may be dangerous.
- 6) Do not touch the machine with wet hands, otherwise it may cause electric shock.
- 7) In thunderstorms, please turn off the main power switch of the machine, otherwise lightning may cause danger or damage the machine.
- 8) The system needs to use an independent power switch to avoid sharing the same circuit with other electrical appliances, and use a power cord with a specified cross-sectional area to provide power to the system, and match the circuit breaker of the corresponding specification (with leakage protection function).
- 9) The system must be installed with a grounding wire with a specified cross-sectional area. Do not connect the grounding wire with gas pipelines, water pipes, lightning conductors or telephone grounding wires, and must be grounded reliably to avoid electric shock accidents.
- 10) Don't cut off the power forcibly when the system is running to avoid accidents.
- 11) When the machine is not used for a long time, please turn off the main power switch to avoid accidents.
- 12) If the ambient temperature is below 0°C, it is strictly forbidden to cut off the power supply. If there is an accidental power failure under this condition, drain the water in the pipeline.

 **Note**

- 1) Do not put your hands or foreign objects into the air outlet of the system, otherwise the high-speed running fan may endanger your safety.
- 2) Do not remove the air guide net cover of the outdoor system, otherwise the high-speed fan may cause injury to you or others.
- 3) Lightning and other sources of electromagnetic radiation may have an impact on this machine. If it does have an impact, please cut off the power supply, and then restart it.
- 4) Pay attention to the water supply of tap water when using.
- 5) Do not switch the system frequently, otherwise it may cause damage to the system.
- 6) The operating parameters of the system and the setting value of the protection device have been set when

the machine leaves the factory. Please do not change the setting value at will, and do not short-circuit the line of the system protection device, otherwise the system may be caused by improper protection. damage.

- 7) The refrigerant used by the system is non-flammable and non-toxic. Because its specific gravity is larger than that of air, it will spread on the ground when it leaks. Therefore, when the system is assembled in the room, it must be well ventilated to avoid serious refrigerant leakage asphyxia.
- 8) In case of refrigerant leakage, immediately stop the operation of the system and contact the maintenance personnel in time. There should be no open flames on site, because the refrigerant will decompose into harmful gases when contacted with open flames.
- 9) In order to avoid frost damage to the water system pipeline, please keep the system charged when the system is out of service in an environment below 0°C. If the system is out of service for a long time, it is recommended that the user drain the water system water and cut off the power supply.
- 10) Please perform regular maintenance on the system according to the instructions to ensure that the system is operating in good condition.

2. Other safety precautions

- 1) Before operating the system, please read all "Safety Precautions" in detail.
- 2) Various important safety-related matters are listed in the "Safety Precautions", please strictly observe them.
- 3) The system must use a fuse with a specified capacity, and cannot be replaced by iron wire or copper wire.
- 4) The working environment of the system should be far away from places with fire hazards. If the wiring problem causes a fire, the main power switch should be turned off immediately and a dry powder fire extinguisher should be used to extinguish the fire.
- 5) The power supply must be cut off before the system is repaired.
- 6) The sharp edges and the surface of the fin are both harmful and should be avoided as much as possible.
- 7) Please do not touch the rotating blades with your hands or other objects, so as to avoid damage to the equipment and casualties.
- 8) It is forbidden to place objects above the system to avoid accidents caused by objects falling when the machine is running.
- 9) The fixed line connected to the equipment must be equipped with an all-pole disconnect device with a contact distance of at least 3mm.
- 10) The equipment should be installed in accordance with national wiring rules.









3. System operating temperature range

- 1) Outdoor ambient temperature for cooling mode: 16~46°C, return water temperature ranges from: 10~25°C;
- 2) Outdoor ambient temperature for heating mode: -30~21°C, return water temperature ranges from: 20~50°C

Controller Instruction



1. Controller



-  ON/OFF: Turn on or turn off heat pump
-  Timer: Timing turn on or turn off heat pump
-  UP: Set temperature higher
-  Down: Set temperature lower
-  Mode: Underfloor heating, radiator heating or cooling
-  Set: Set back end parameter



2. Operation instruction

2.1 Turn ON & Turn OFF

- 1) In the off state, click the “on/off” button after the controller is unlocked, the machine will be turned on immediately. Otherwise, it will be turned off.
- 2) Unlock/lock button: Press the “On/Off” button for 3 seconds to unlock the controller. No button operation for 30 seconds, the brightness of the LCD display is automatically dimmed, and the “button locked” state is automatically activated.
- 3) LCD display: The icon  disappears to exit the “lock button” status, and the icon  lights to enter the “lock button” status.

2.2 Switch operation mode

In the power-on state, after unlocking, press the “Mode” button to switch the operation mode. There are three modes to switch, which are the underfloor heating, radiator heating and cooling modes

 — Floor heating mode;  — Heating mode;  — Cooling mode;

2.3 Set water inlet temperature

In the power on state, after unlocking, press the “Up” or “Down” button to adjust the setting temperature

2.4 Clock setting

2.4.1 Enter clock setting: When the controller is powered on, press and hold the “Timer” button for 5 seconds, and the hour portion of the clock area is flashing, which indicates that the clock setting state is entered;

2.4.2 Clock setting operation: Enter the clock setting state, the hour part is flashing, press the “Up” or “Down” button to modify the hour part, then press the “Timer” button, the minute area is flashing, press the “Up” or “Down” button to modify the minute part. Press the “Timer” button or no button operation for 20 seconds, Save your current settings and exit.

2.4.3 Set timer control

2.4.3.1 Timing settings can be set separately for two time periods, which are “1” and “2” for each period. Each group of time periods can be set to “Timed Power On” and “Timed Power Off”; when “Timed Power On” and “Timed Power Off” are set at the same time, it is taken as "invalid" status.

2.4.3.2 Enter timing settings:

- 1) Click the “Timer” button, the “1” and “ON” icons at the bottom right of the screen are displayed, and the hour display area is flashing, which indicates that the “the 1st time period turn on” setting state is entered. The hour area is flashing, press the “Up” or “Down” button to modify the time, then press the “Timer” button to confirm the modification and transfer to the minute setting. the minute area is flashing, then press the “Up” or “Down” button to modify the time, and then press the “Timer” button to confirm the modification.
- 2) After the “Timed Power On” is set, enter the “Timed Power Off” setting. When the “1” and “OFF” icons are displayed at the bottom right of the screen, it means to enter the “the 1st time period turn off” setting state, the hour area is flashing, press the “Up” or “Down” button to modify the time, then press the “Timer” button to confirm the modification.

“down” button to modify the time, then press “Timer” to confirm the modification and transfer to the minute setting. The minute area is flashing, then press the “Up” or “Down” to modify the time, then press “Time” to confirm the modification. Enter the timing setting of "Time Period 2".

- 3) "Time Period 2" setting operation is the same as above.

2.4.3.3 Exit setting timing:

When setting the timing state, press the “switch” button or no button operation for 20 seconds to exit setting time.

Cancel the timing setting: Entering the timing setting state, press and hold the “Timer” button for 5 seconds to cancel the exist time period.

5. Booster mode:

- 1) In the power-on state, in the radiator heating or floor heating mode, press and hold the “Function” button for 3 seconds to enter the booster mode, then press the “Function” button or the “On/Off” button to exit the booster mode.
- 2) Booster mode description: the heat pump and electric heating element are turned on at the same time
- 3) LCD display: "Boost icon" lights up.

6. Forced defrost function:

- 1) In the power-on state, in the heating or floor heating mode, press the “Function” button + “Up” button simultaneously for 5 seconds to enter the defrost mode.
- 2) LCD display: "Defrost icon" lights up.

7 Refrigerant recovery function:

- 1) In the off state, long press the “Mode” button + “Up” button for 5 seconds to enter; press the “Mode” button + “Up” button to exit.
- 2) LCD display: The cooling icon flashes and the temperature zone shows the evaporation temperature value.

8. Waterway emptying mode:

- 1) In the off state, press the “Mode” button + “Down” button simultaneously for 5 seconds to enter; press the “Mode” button + “Down” button to exit.
- 2) LCD display: "Pump icon" flashes.

9. Running parameter query

Press the “Mode” button for 3 seconds to enter the running parameter query state during the power on or off state, press the “Up” or “Down” button to scroll through the line to display the “Running Parameters”; the temperature display area displays the

parameter serial number, and the timed area displays the parameter content. Press the “ON/OFF” button or the no button operation for 20 seconds to automatically exit the running parameter query status.

Operation Parameter Query

Query code	Description	Range
1	Compressor running frequency	0~99Hz
2	Fan motor running frequency	0~99Hz
3	Main EEV opening	0~480P
4	EVI EEV opening	0~480P
5	AC input voltage	0~500V
6	AC input current	0~50.0A
7	Compressor phase current	0~50.0A
8	Compressor IPM mould temperature	-50~200℃
9	Condensing temperature	-50~200℃
10	Vaporization temperature	-50~200℃
11	Outdoor ambient temperature	-50~200℃
12	Outdoor coil temperature	-50~200℃
13	Indoor coil temperature	-50~200℃
14	Gas suction temperature	-50~200℃
15	Gas exhaust temperature	-50~200℃
16	Water inlet temperature	-50~200℃
17	Water outlet temperature	-50~200℃
18	Economizer inlet temperature	-50~200℃
19	Economizer outlet temperature	0~15
20	Dial-er value	

10. Error code:

When the machine has a fault, the fault is flashing in the timing area, and the fault code is displayed cyclically; when the fault is eliminated, the normal display is restored.

Fault code	Fault Description	Fault code	Fault Description
E 01	False protection	E 24	Gas temperature sensor fault
E 02	Lack of protection	E 25	Exhaust sensor fault
E 03	Main side water switch protection	E 26	Backwater temperature sensor fault
E 04	Heating Side Water Switch Protection	E 27	Outlet temperature sensor fault

E 05	High voltage switch protection	E 28	Water tank temperature sensor fault
E 06	Low voltage switch protection	E 29	Reservation
E 07	Excessive protection of inlet and outlet pipes	E30	IPM overcurrent
E 08	Excessive exhaust protection	E31	Compressor drive failure
E 09	Protection over high pressure	E32	Overcurrent compressor
E 10	Low pressure protection	E33	Reservation
E 11	Unit water temperature too low protection (sound alarm)	E34	Compressor phase current sampling fault
E 12	Failure of four-way valve switching	E35	Radiator overheating shutdown
E 13	Reservation	E36	Reservation
E 14	Reservation	E37	DC bus overvoltage
E 15	Reservation	E38	DC bus undervoltage
E 16	Main Control and Line Controller Communication Fault	E39	AC input undervoltage
E 17	Reservation	E40	AC input overcurrent
E 18	High voltage sensor fault	E41	Input voltage sensor sampling fault
E 19	Low voltage sensor fault	E42	DSP and PFC communication failures
E 20	Failure of indoor temperature sensors	E43	Radiator sensor fault
E 21	Failure of outdoor ambient temperature sensor	E44	Drive DSP internal communication failure
E 22	Failure of temperature sensor of outer coil	E45	Abnormal communication between drive and main control board
E 23	Inner Heat Exchanger Temperature Sensor Fault		

Dimension & Drawing

Dimension of Outdoor Unit

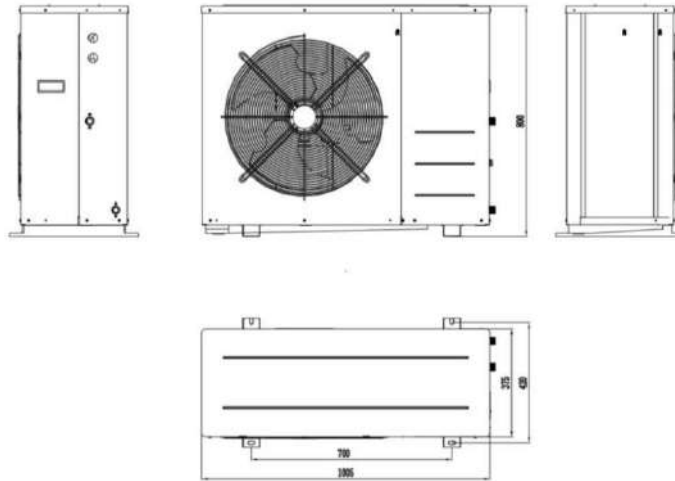

Explosive Drawing Outdoor Unit

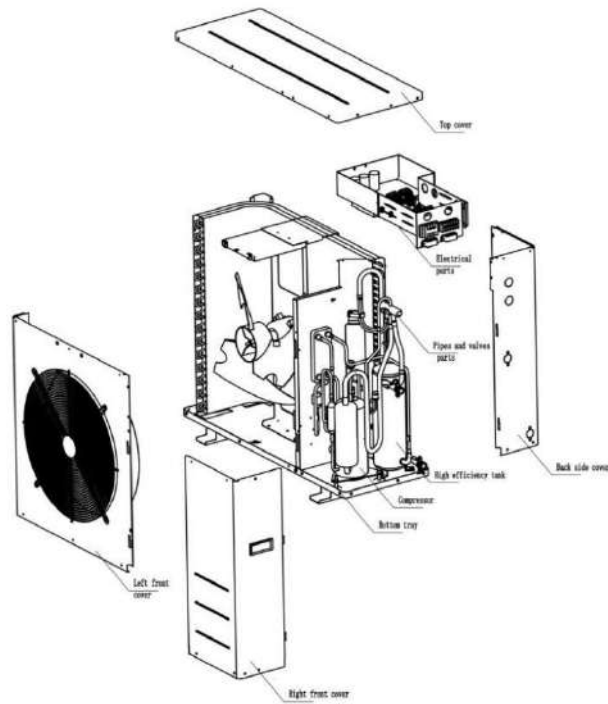

Dimensions of Indoor Unit(Hydraulic Module)

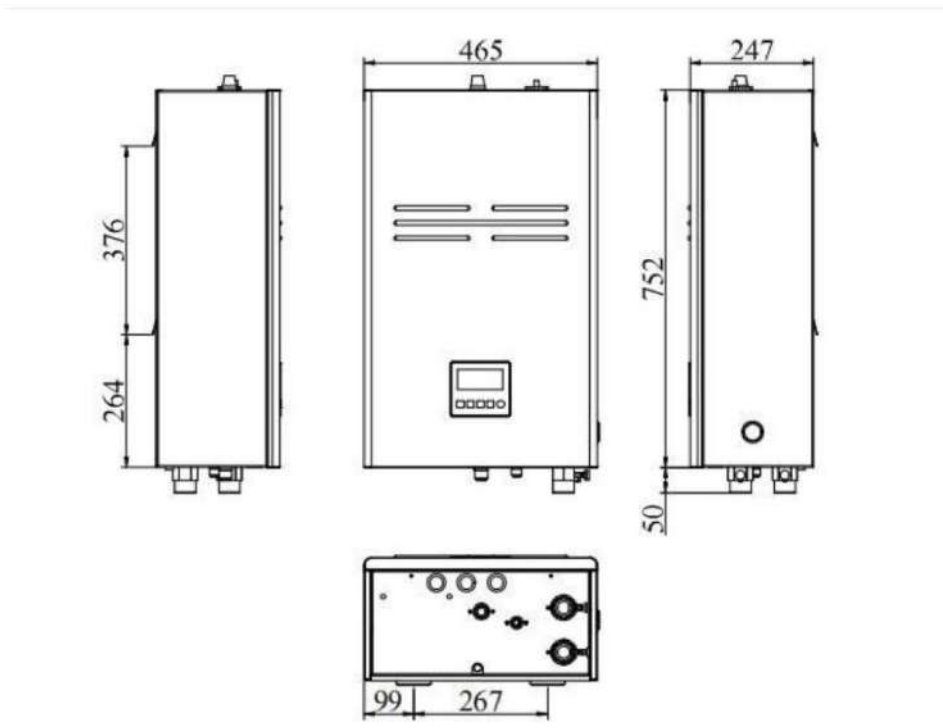

Explosive Drawing of Indoor Unit(Hydraulic Module)

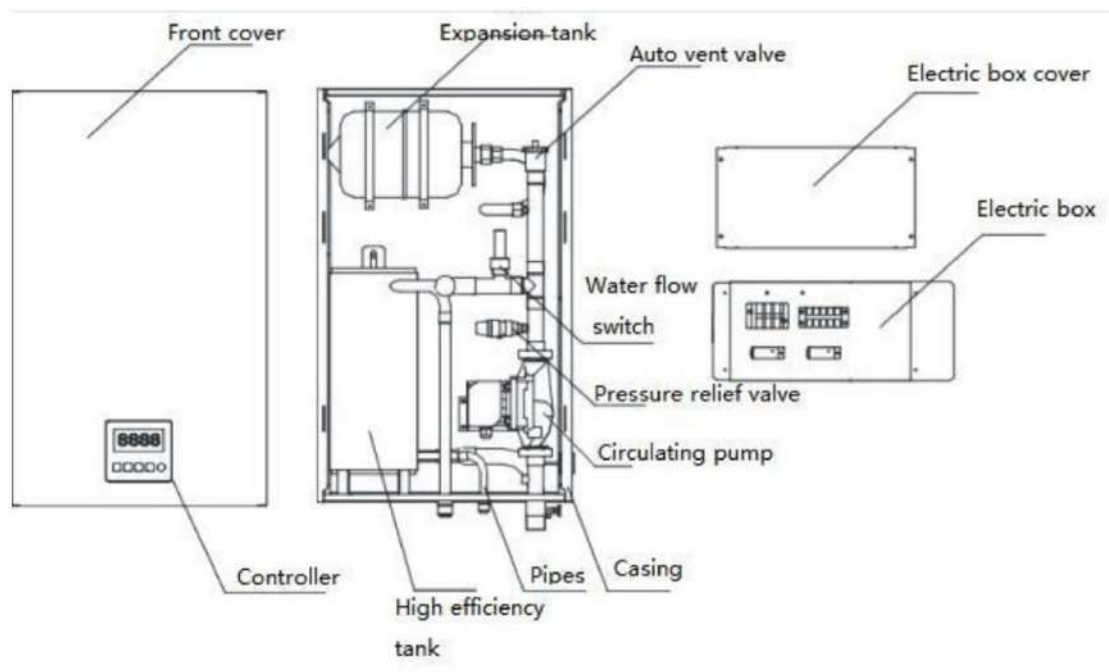

Installation

1. Installation preparation

1) Install the required tools (self-provided)

No.	Tool	No.	Tool
1	Gradienter	10	Saw
2	Electric hammer	11	Flat blade screw driver
3	Adjustable wrench	12	Cross screw driver
4	Needle-nose plier	13	Copper tube knife
5	Impulse drill	14	PP-R tube knife
6	Ruler	15	PP-R tube heat melting device
7	Torque wrench	16	Compound gauge
8	Hexagonal wrench	17	Vacuum pump
9	Hammer	18	Electronic balance

2) Connecting copper pipes, connecting wires and insulation materials, pipes and connectors,

- a. please refer to relevant requirements to purchase or order from our company;
- b. insulation pipe material and thickness meet the specified requirements, otherwise heat loss and condensation will be caused;
- c. For selecting proper wire, please refer to the "Electrical Installation" section of this manual;

Model	Connecting copper pipes for refrigerant(mm)	Connecting pipes for water(male)
BLN-012TA1S	19.05/12.7	DN32

3) Other required materials for installation

- a. Pipe holders and pipe clamps for fixing connecting pipes
- b. Wire threading pipes and pipe clamps
- c. Insulation tape, raw material tape
- d. Expansion bolts
- e. Outdoor system mounting bracket
- f. R410A refrigerant bottle

Piping Instruction

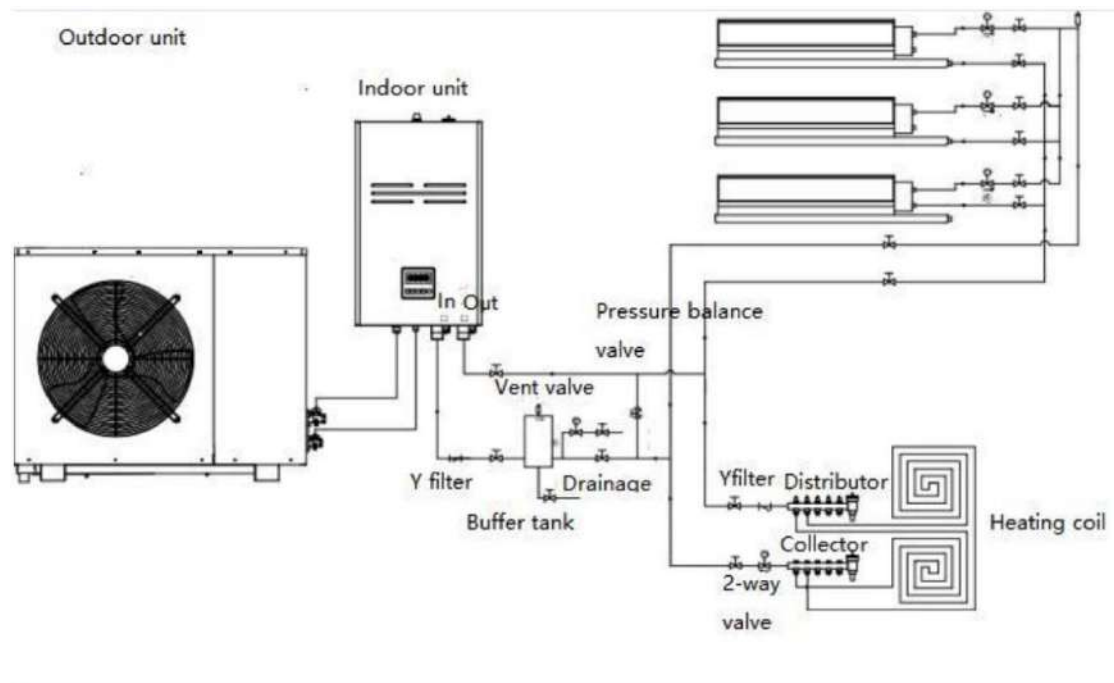

Remarks:

- 1) The automatic vent valve is installed at the highest point of the system pipe road, and the water pipe at the installation location must have an enlarged diameter;.
- 2) The drain valve is installed at the bottom of the pipeline, which is conducive to drainage;.
- 3) The same pattern of pipes is conducive to uniform water flow distribution;
- 4) Install pressure balance valves in the inlet and outlet water mains to avoid insufficient water flow alarms in the waterway; .
- 5) Normal working water capacity can ensure normal defrosting in winter to ensure that each water capacity exceeds 10L;
- 6) The system to install an automatic water supply valve and the highest point self-exhaust valve.

2. Installation location selection

Outdoor unit

- 1) The machine installation space meets the following schematic requirements to ensure normal air circulation and maintenance;
- 2) Please try not to install the outdoor unit in direct sunlight. If necessary, install an awning that does not affect the wind output of the system;
- 3) The installation location of the outdoor unit should be far away from heat, steam or flammable gas;
- 4) Do not install the machine in places with strong wind or dust;
- 5) Do not install the machine where it is often passed through the air suction side and air exhaust side;
- 6) The installation position of the machine should be properly drained to the nearby sewer.

Outdoor Unit Installation Space Diagram

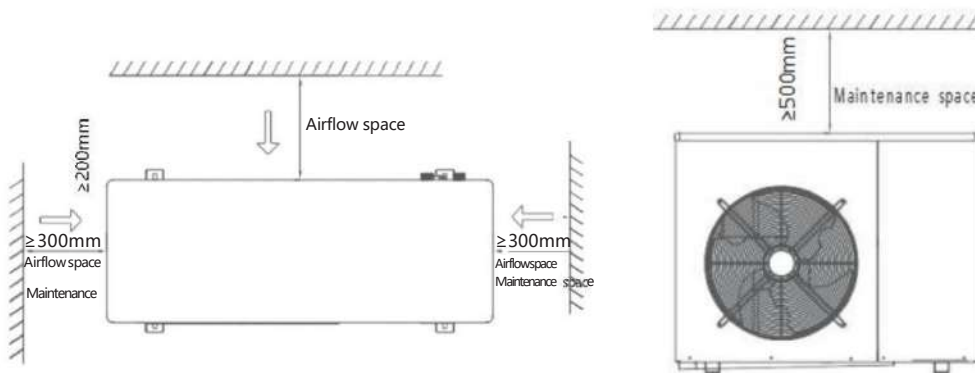

Note

Installation in the following locations may cause the machine to malfunction:

- 1) A place with more oil;
- 2) Wet place;
- 3) Seaside saline-alkali area;
- 4) Special environmental conditions;
- 5) High-frequency facilities such as wireless equipment, welding machines and medical equipment.

Hydraulic module

- 1) The installation space of the hydraulic module meets the requirements of the schematic diagram to ensure normal maintenance;
- 2) The hydraulic module is installed at a position above zero degrees Celsius;
- 3) The installation position of the hydraulic module should not affect people's normal life and rest, and avoid hearing the system work, the sound of refrigerant, water pump and water flow;
- 4) The installation position of the hydraulic module should ensure that the length of the connecting pipe with the outdoor system is less than 10 meters, and the drop is less than 5 meters.

Installation space requirements for hydraulic modules

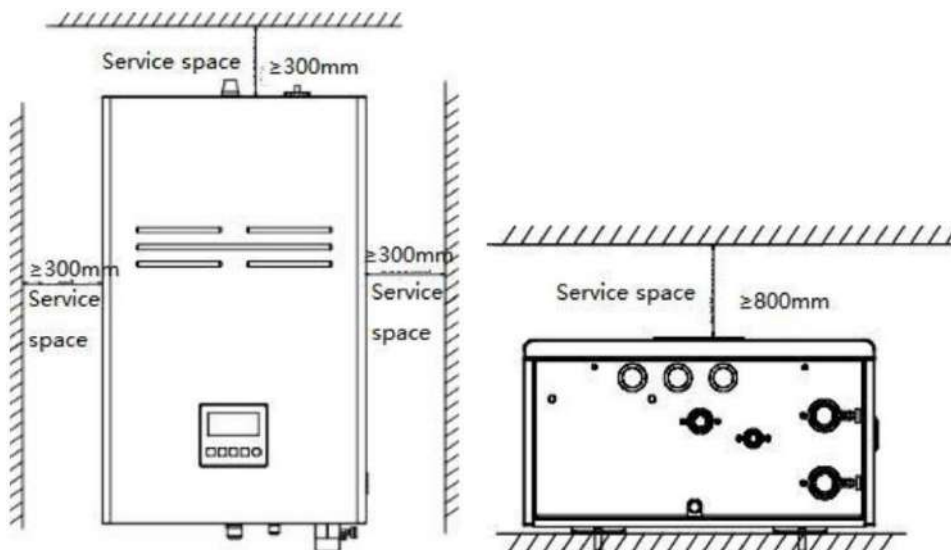

3. Connection of outdoor system, hydraulic module and waterway

Installation of outdoor system

To ensure safe and reliable installation of the system and minimize vibration, the system should be installed on a solid surface such as concrete, a load-bearing surface or mounting bracket. Need to meet strength requirements.

Installation basis of outdoor system

The positioning size of the outdoor system installation foundation is 810* 394mm, and a positioning foot bolt with a diameter of is required to be installed. The recommended dimensions of the outdoor system installation base are: 1200 *450mm

NOTE:

- 1) The system should be installed so that the inclination of any vertical surface does not exceed 5 degrees;
- 2) Do not install the outdoor system directly on the ground;
- 3) The strength of the ordinary air conditioner bracket may not be suitable for the system, please design or select the bracket according to the weight of the system.
- 4) If the host is installed and fixed on the open balcony and roof, the system needs to be hoisted, and the following points should be paid attention to when hoisting:
 - a. Please use a softer lifting belt above the strip to lift the handling system;
 - b. To avoid scratches on the surface of the system, Deformation, please add a protective plate on the surface of the system when hoisting and handling;
 - c. Before the final hoisting and installation, the foundation needs to be checked again to ensure that it is not in error with the actual object.

The installation and installation steps of the hydraulic module are as follows:

- 1) Drill a hole of $\phi 12 * 80$ on the solid wall where the hydraulic module is to be installed according to the distance requirements of the mounting and fixing holes of the rack;
- 2) Install 4 pcs of M10* 80 expansion bolt into the drilled hole;
- 3) Install the module mounting bracket to the location where the expansion bolts are located, and fix each bolt with a nut;
- 4) Install the hydraulic module on the bracket.

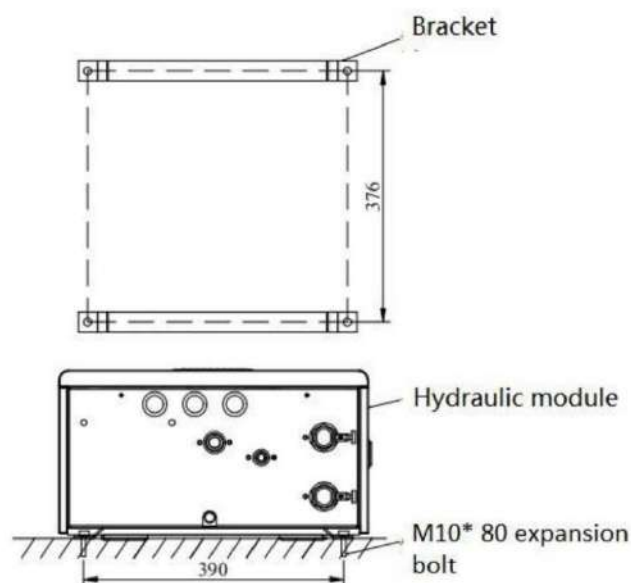

4. Installation of hydraulic module and user end waterway system

The installation of waterway system shall comply with the following principles:

- 1) The length of the water pipe should be as short as possible;
- 2) The diameter of the water pipe must meet the requirements of the system;
- 3) The elbows on the waterway should be as few as possible, and the radius of the elbow should be as large as possible;
- 4) The thickness of the water pipe insulation layer should meet the specified requirements.

Waterway system installation steps:

- 1) Install all water pipes;
- 2) Keep the pressure of the water pipes for leak detection;
- 3) Clean the water pipes;
- 4) Steps for water refilling and emptying of the water pipes:
 - a. First open the vent valve and all valves on the water distributor;
 - b. Make up water at the water supply port of the pipeline;
 - c. During the water supply process, you need to observe the exhaust valve and the drain valve to see if there is water flowing out. If there is water overflow, it means the water system is fully filled;
 - d. Close the vent valve; then look at the water pressure gauge, if the pointer is greater than 1.5Bar, you can close the water supply valve, and the waterway is drained.

5. Refrigerant piping installation between outdoor unit and hydraulic module

The steps of connecting outdoor unit and hydraulic module fluorine circuit are as follows:

- 1) Remove the cap or valve cap on the hydraulic module and the stop valve head of the outdoor system;
- 2) Connect the copper pipe of the corresponding specification (set the insulation Pipe) Put the bonnet just removed to expand;
- 3) Fix the connecting pipe on the outdoor system shut-off valve and hydraulic module connector through the bonnet, and tighten the bonnet;
- 4) Choose any shut-off valve needle port of the outdoor system, connect the pressure gauge to vacuum;
- 5) After the vacuum is completed, hold the pressure to ensure that there is no leakage;
- 6) Open the two shut-off valves completely, and remove the pressure gauge connecting pipe

Pipe length and height difference requirements of outdoor unit and hydraulic module

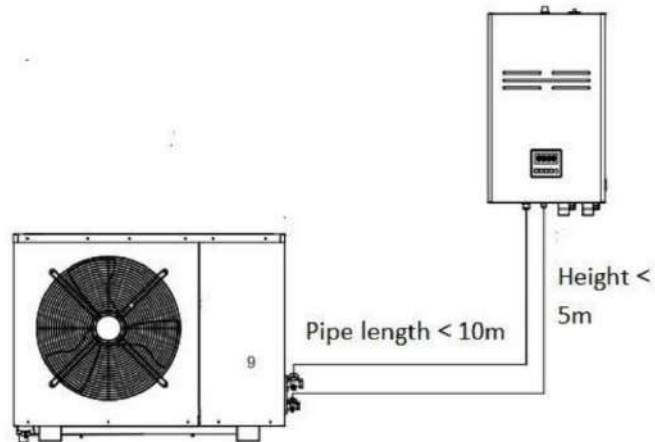

Refrigerant connection pipe installation

1. Flaring

- 1) Use a pipe cutter to cut the connecting pipe to the required length. It is recommended to cut the length to be 30cm longer than the actual requirement;
- 2) Use a pipe cutter to remove the burrs on the copper pipe port. The port faces downward during operation to ensure that the copper scraps are not Drop into the copper pipe;
- 3) Remove the nut from the system and put it on the copper pipe;
- 4) Use a flaring tool to expand the end of the copper pipe.

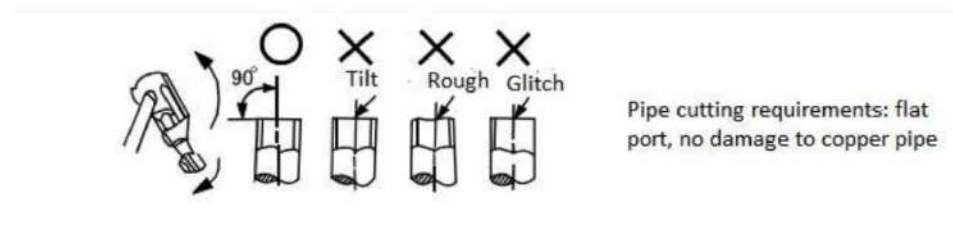

Flaring requirements: smooth inner and outer surfaces, uniform length on the cone side.

The specific size requirements of the bell mouth are as follows:

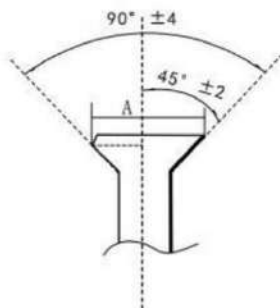

Diameter of liquid side piping	Additional refrigerant charge per meter
φ 9.52	50 g/m
φ 12.7	100 g/m
φ 15.88	170 g/m
φ 19.05	220 g/m

2. Fasten the joint

- 1) Before using the copper pipe, make sure to use a sealing cap or preventive tape to prevent dust or water from entering the copper pipe;
- 2) For a correct connection, align the joint with the flared pipe and tighten the nut slightly;
- 3) Use a torque Tighten the nut at the flare with a wrench.



Note

Depending on the installation conditions, excessive torque will damage the flaring and nuts.

Copper pipe diameter and wrench torque reference table

Outer diameter	Torque force
φ 6.35mm	1420~1720N cm (144~176kgf. cm)
φ 9.52mm	3270~3990N cm (333~407kgf. cm)
φ 12.7mm	4950~6030N cm (504~616kgf. cm)
φ 15.88mm	6180~7540N cm (630~770kgf. cm)
φ 19.05mm	9720~11860N cm (990~1210kgf. cm)

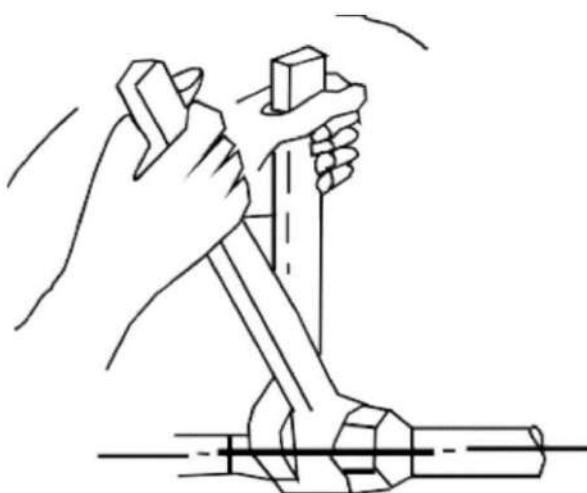

3. Air removal (A5mm hexagon wrench is required)

- a. The air in the indoor system and outdoor connection pipes needs to be removed with a vacuum pump: see the section on using a vacuum pump.
- b. If the system is moved to another place, use a vacuum pump to vacuum.
- c. It is strictly prohibited to use the host refrigerant gas for air removal.

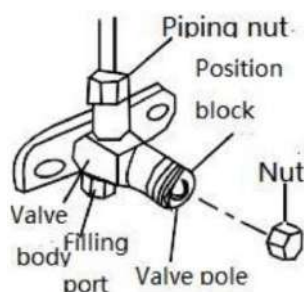
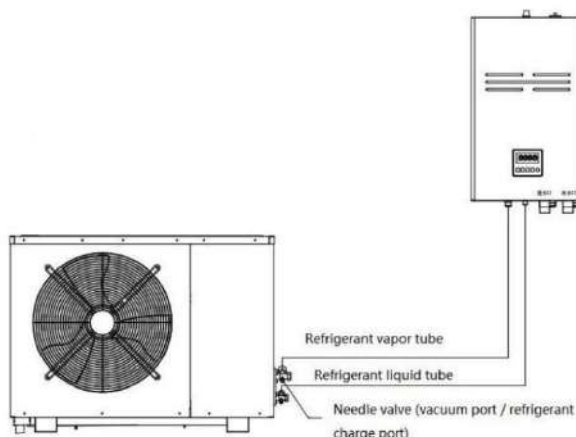

4. Vacuum pump operation

- a. Connect the pressure gauge hose to (the shut-off valve is closed).
- b. Connect the connector to the vacuum pump.
- c. Fully open the handle.
- d. Start the vacuum pump to vacuum. When starting to vacuum, slightly loosen the connecting nut of the low pressure valve, check whether air enters (the noise of the vacuum pump changes, and the multimeter indicator changes from negative to 0), and then tighten the connecting nut.
- e. After the vacuum is completed, completely close the handle and stop the vacuum pump. Keep the pressure for more than 10 minutes and confirm that the pointer of the multimeter is on the -1.0×10^5 Pa (-76cmHg) scale.
- f. Fully open the stop valves on both sides of the high and low sides.
- g. Remove from.
- h. Tighten up. Use pressure gauge hose, pressure gauge low pressure valve, pressure gauge high pressure valve, pressure gauge hose, liquid shut-off valve filling port, liquid shut-off valve charge

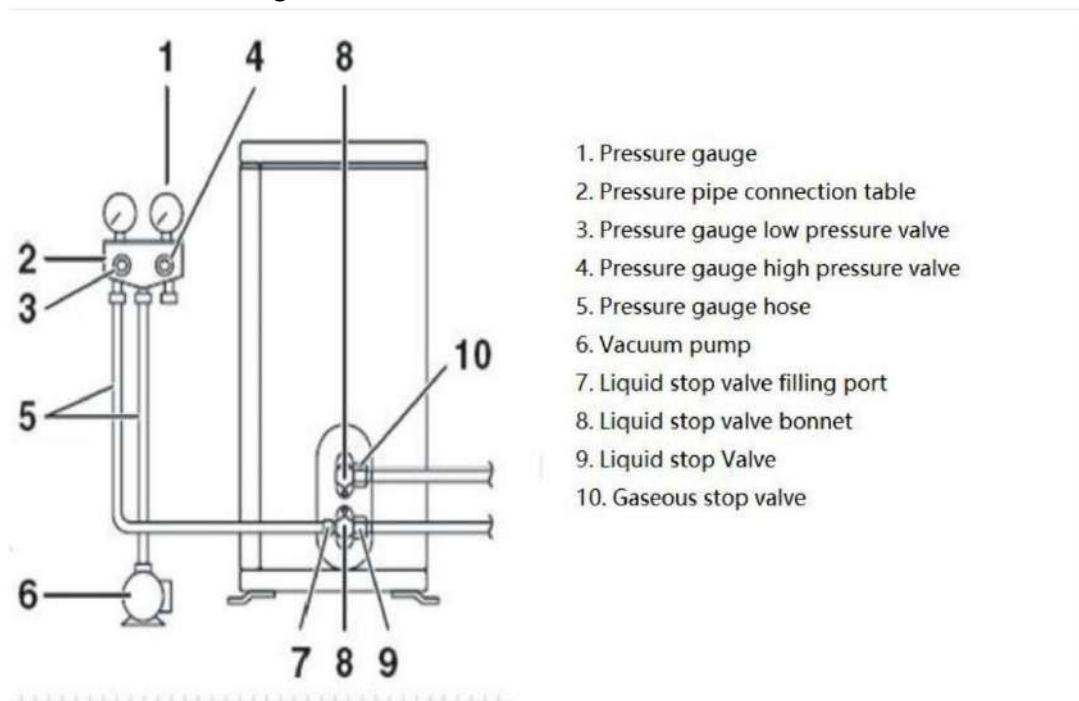

5. Additional refrigerant

- a. One-way pipe length or less 5m (including 5m), no additional refrigerant is required.
- b. If the one-way pipe length is 5m above, additional refrigerant must be added, and the filling amount is specified in the following table.)

Diameter of liquid side piping	Additional refrigerant charge per meter
φ 9.52	50 g/m
φ 12.7	100 g/m
φ 15.88	170 g/m
φ 19.05	220 g/m

- c. If the length exceeds the reference length, additional refrigerant must be added strictly in accordance with the length of the connecting pipe.)
- d. Please record the refrigerant charge and keep it properly for future maintenance
- e. For R410A refrigerant models, when filling refrigerant, be sure to use liquid refrigerant.
- f. It is strictly forbidden to charge other types of refrigerants, otherwise it will cause damage to the system.

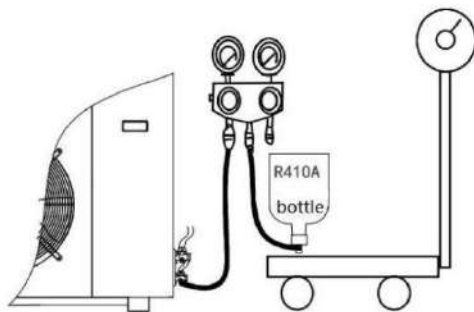

Note:

1. If you use a refrigerant bottle with a siphon tube, there is no need to invert the refrigerant bottle when filling. Please check the type of the refrigerant bottle before filling;
2. The R410A refrigerant bottle has a pink body

- g. When the system is filled with refrigerant under heating conditions, the refrigerant must be filled at the needle valve side of the suction pipe, as shown below:

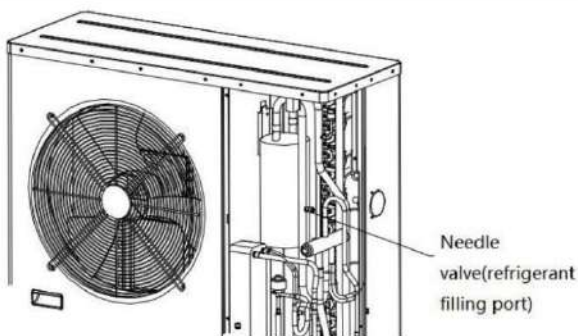

Note:

1. When filling refrigerant, be sure to charge it in liquid state;
2. When adding refrigerant on the suction side, the valve opening of the refrigerant should be small, so that the refrigerant in the refrigerant bottle enters the system slowly to prevent liquid shock.

6. Check refrigerant leakage

- a. Use soapy water or a leak detector to check for leaks at all joints.
- b. When refrigerant leakage occurs, the leakage point must be found, and the leakage point must be reconnected or repaired; when the leakage point is repaired or reconnected, it must be ensured that there is no refrigerant or other pressure in the system, otherwise it is easy to cause The copper pipe was burst by refrigerant pressure or other pressure, causing accidental injury to the operator.
- c. When refrigerant leakage occurs in a narrow space, in order to prevent suffocation accidents, all vents should be opened or forced ventilation to discharge the refrigerant before relevant operations.

Electrical Installation

All wiring and grounding must comply with local electrical codes.



Note

- 1) The specification label should be carefully checked to ensure that the wiring meets the specified requirements and is correctly wired according to the wiring diagram;
- 2) Outdoor system should be equipped with independent power supply with current circuit breaker and leakage protector;
- 3) The power supply must meet the requirements of the machine and must be reliably and effectively wired;
- 4) Wires should not be in contact with copper pipes, compressors, motors or other operating components;
- 5) Do not change the internal wiring of the machine without permission, otherwise the seller will not commit any responsibility;
- 6) Do not send power before the wiring is completed, so as to avoid personal injury;
- 7) The supply voltage should vary within $\pm 10\%$ of the standard value.

Electrical specifications

Model	Power supply	Max input current	Fuse(A)	Electric leakage protector(mA)	Power cable (mm ²)
BLN-012TA1S	220V/50Hz	24A	25A	30mA	6

Power cable and signal wire connection instruction

- 1) Remove the outdoor system maintenance board and the front panel of the hydraulic module, and connect the wire to the corresponding terminal block according to the electrical wiring diagram to confirm that the connection is secure.
- 2) Secure the cable with the wire clamp and install the service plate and front panel of the hydraulic module.
- 3) Do not connect the wrong line, otherwise it will cause electrical failure or even damage the machine.
- 4) The type and rating of the fuse are based on the specifications on the corresponding controller or fuse cover.
- 5) The power cable must be selected and installed by the professional installer. When the installer selects the power cable, the power cable should not be lighter than the neoprene armored cord (line 57 of IEC 60245). For specific power cable specifications, see the electrical specifications. .
- 6) If the user's power distribution capacity is insufficient or the power cord (copper core wire) is not configured as required, the machine cannot be started or operated normally, the seller will not take any responsibility.

Electrical Wiring Diagram For Outdoor Unit

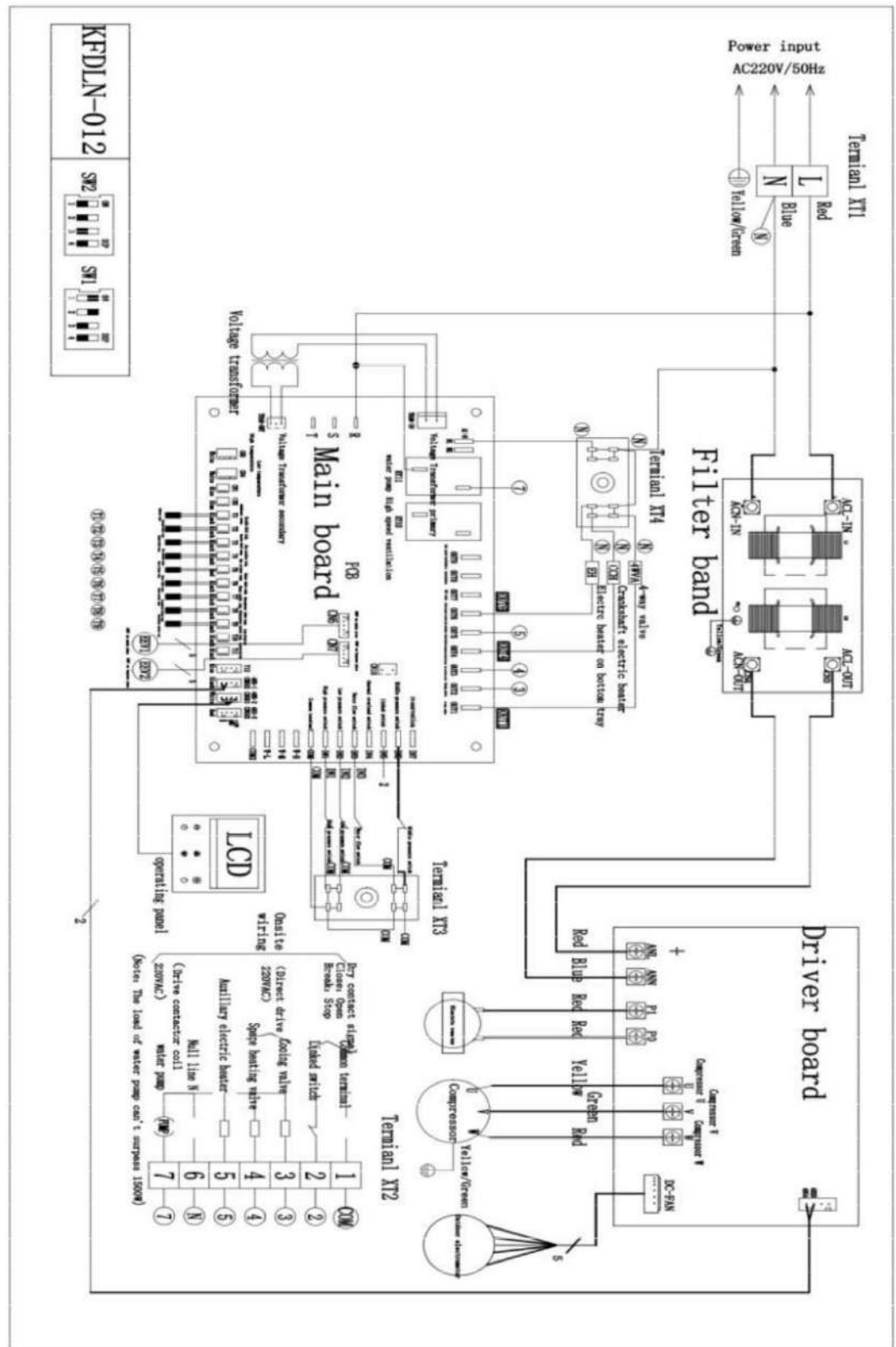

Electrical schematic diagram of hydraulic module

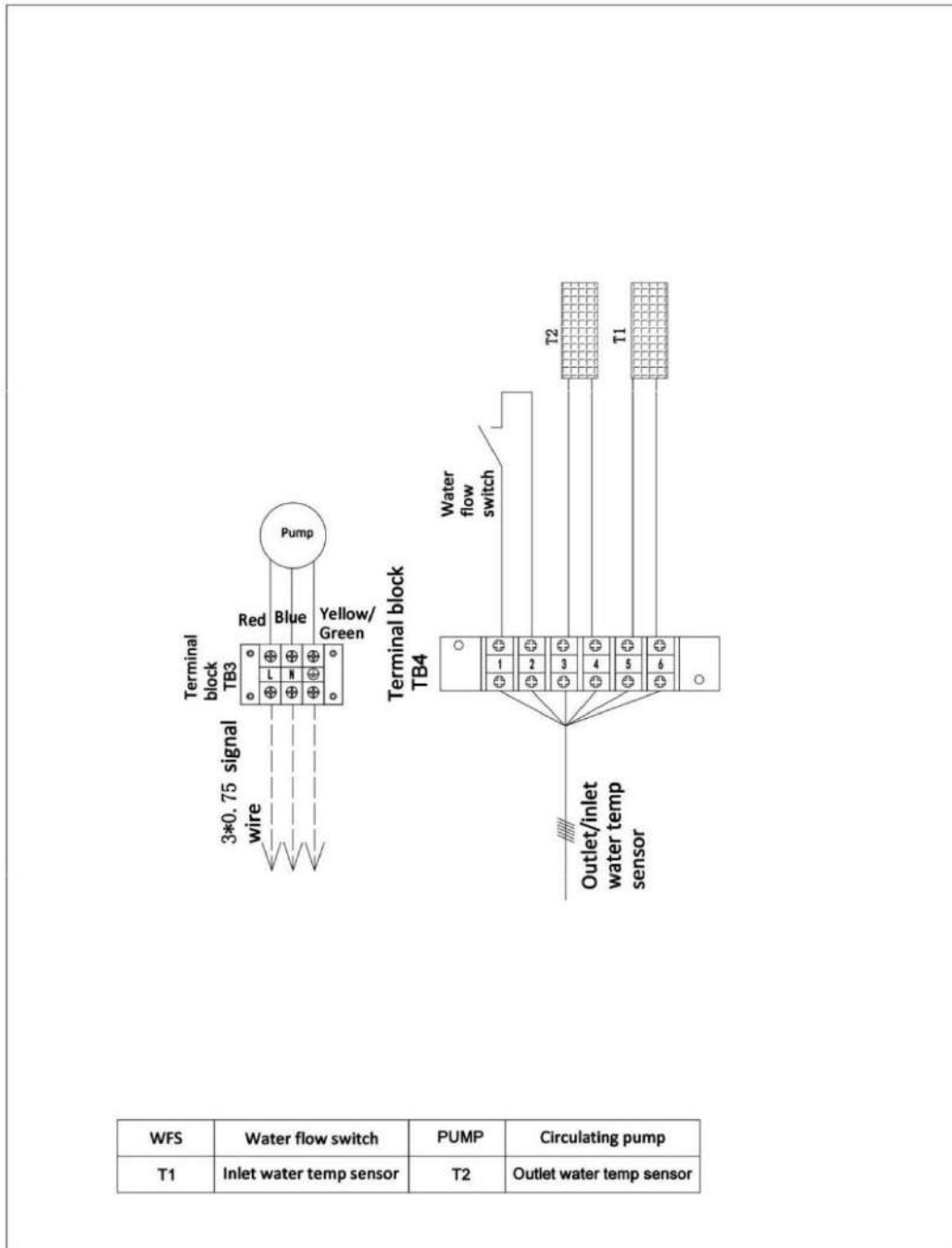

Outdoor unit wiring diagram

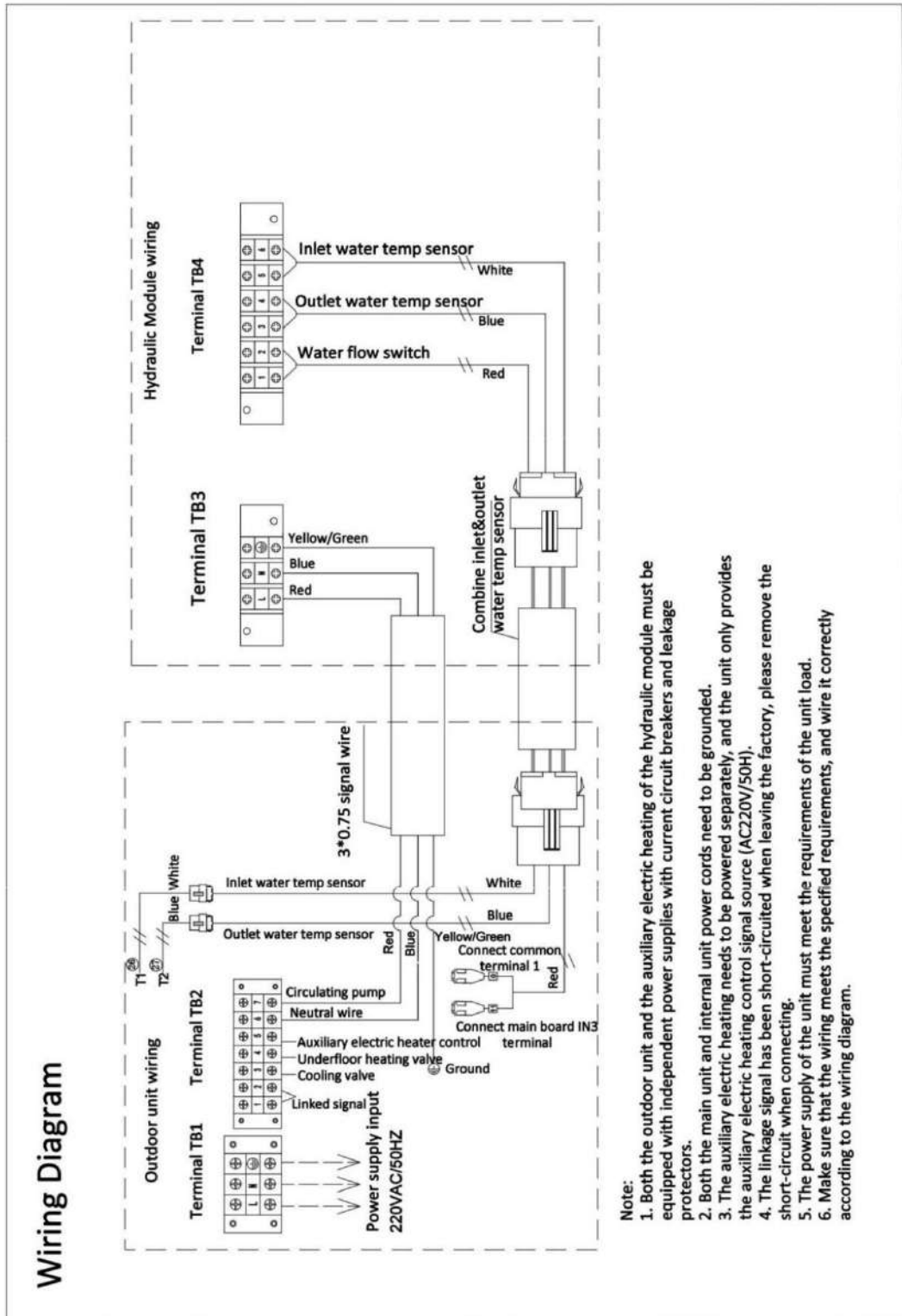

Commissioning

1. Precautions before commissioning

- 1) Is the machine properly installed;
- 2) Is the wiring and piping correct;
- 3) Whether the water pipelines is empty or not;
- 4) Whether the heat insulation has been perfected;
- 5) Is the ground wire connected reliably;
- 6) Whether the power supply voltage matches the rated voltage of the machine;
- 7) Is there any obstacle in the air inlet and outlet of the machine;
- 8) Is the safety valve installed correctly;
- 9) Whether the leakage protector can operate effectively;
- 10) The system water pressure is not less than 0.15MPa, and the maximum pressure cannot exceed 0.5MPa;
- 11) In winter, the machine needs to be energized at least 24 hours earlier before operation as the compressor needs to be preheated.

2. Commissioning

Use the controller to control the machine operation and check the following items according to the instruction manual:

(If there is any fault, please find out the faults and reasons described in the manual and eliminate them)

- 1) Is the controller normal?
- 2) Is the function key of the controller normal?
- 3) Is the drainage normal?
- 4) Test whether the heating mode and cooling mode are working properly;
- 5) Is the outlet water temperature normal?
- 6) Whether there is vibration and abnormal sound during operation;
- 7) Does the generated wind, noise and condensate affect neighbors;
- 8) Is there refrigerant leakage.

3. Operation and debugging

- 1) About 3mins of protection
Due to the self-protection of the compressor, the machine cannot be restarted again within 3 minutes
- 2) Feature of heating operation

During operation, if the ambient temperature is too high, the outdoor motor may run low or stop.

3) About defrosting during heating operation

In the case of heating operation, when the system has frost formation, the defrosting operation (about 2-8 minutes) is automatically performed to improve the heating effect. The outdoor motor stops running during the defrost operation.

4) Power outage

If there is a power outage during operation, then the machine will stop running. Before the power outage, the controller automatically memories the ON/OFF status of the machine. After re-powering, the controller will send an ON/OFF signal to the machine according to the state of memory before power outage to ensure that the machine recovers back to previous status from abnormal power failure.

5) Heating capacity

Because the heat pump absorbs heat from the outside, once the outdoor temperature is lowered, the heating capacity will be reduced.

6) Electric leakage protector

After the system has been running for a period of time (usually one month), the leakage protector needs to press the test button under the closed energized state to check whether the performance of the leakage protector is normal and reliable (the leakage protector should be disconnected once every time the test button is pressed) If the accident is not found, the test is allowed to be sent once. If it is not working, the cause should be found out, and if necessary, the action characteristic test should be carried out. After checking, it is confirmed that the leakage protector itself has failed. It should be replaced or repaired in time.

7) Working temperature range

In order to use the machine correctly, please operate under the following conditions, outdoor temperature: $-30^{\circ}\text{C} \sim 46^{\circ}\text{C}$.

8) Antifreeze in the winter

When the ambient temperature is below 0°C , it is strictly forbidden to cut off the power. If there is an unexpected power failure under this condition, please drain the water from the system.

Maintenance

- 1) Please check whether the grounding wire is connected reliably before use. If there is any abnormality, please replace it in time.
- 2) Please check the air inlet and outlet of the outdoor system regularly for blockage.
- 3) Professional are required to clean outdoor system heat exchanger, casing and water circulation piping. It is recommended to clean the filter of the water side filter regularly (cleaning is usually done once a year, depending on the actual situation).
- 4) Regularly check that the safety valve is working properly, and ensure that the drain can be drained normally by manually turning the red knob (usually once every three months, depending on the actual situation).
- 5) Regularly (usually once a year, but depending on the actual situation) Check whether the water pipe joint and the refrigerant connection pipe are leaking or leaking refrigerant (there are oil leakage marks). If there is any leak, please contact the seller.
- 6) The machine can only be serviced by professional. The machine must be cut off before contacting the wiring part.
- 7) Once the machine will not be used for a long time, please cut off the power, drain the water in the pipeline, and close each valve.

Warning

When the fin heat exchanger is cleaned with a cleaning agent (acid or alkaline), it must be completed by a professional company. Corresponding protective measures should be taken during operation, such as goggles, masks, protective gloves, protective shoes, protective clothing, etc. To protect the safety of personnel, please follow the relevant instructions for the use of chemical agents, otherwise it may cause serious personal injury.

Trouble shooting

Error code	Fault description	Failure causes
E 01	Power supply incorrect phase	Power phase incorrect PCB failed
E 02	Power supply lack of phase	Power supply lack of phase PCB failed
E 03	Outside water flow switch fault	<ol style="list-style-type: none"> 1. Circulating pump failed or water system blocked 2. Water flow switch failed or opposite installed direction 3. The lift of circulating pump is not enough 4. Circulating pump has opposite installed direction
E 04	Heating side water flow switch fault	Same as above
E 05	High pressure fault	<ol style="list-style-type: none"> 1. High pressure switch failed 2. Excessive refrigerant 3. Fan doesn't work well or water circulated abnormally 4. Air or other objects mixed into the refrigeration system 5. Too much scale in water heat exchanger
E 06	Low pressure fault	<ol style="list-style-type: none"> 1. Low pressure switch fault 2. Lack of refrigerant 3. Fan doesn't work normally 4. Block exists in refrigeration system
E07	Temperature difference is too big between water inlet and water outlet	<ol style="list-style-type: none"> 1. Water circulating volume is not enough 2. Water temperature sensor failed
E08	Gas exhaust temperature too high	<ol style="list-style-type: none"> 1. Sensor or sensor wire failed 2. Lack of refrigerant 3. Air mixed into the refrigeration system 4. Fan doesn't work normally or heat cannot be dismissed sufficiently 5. EEV opening is abnormal 6. PCB failed
E09	High pressure fault protection	<ol style="list-style-type: none"> 1. Excessive refrigerant 2. Fan doesn't work normally or water circulated abnormally 3. Air or other objects mixed into the refrigeration system 4. Too much scale in water heat exchanger 5. High pressure sensor failure
E10	Low pressure fault	<ol style="list-style-type: none"> 1. Low pressure switch fault 2. Lack of refrigerant 3. Fan doesn't work normally 4. Block exists in the refrigeration pipes 5. Ambient temperature too low

E 11	Water temperature too low (buzzer activated)	1. Water temperature is too low 2. Heat is not produced enough or heat pump failed
E 12	4-way valve fault	1. 4-way valve fault 2. PCB or controller failed
E 16	Communication fault between controller and PCB	1. PCB or controller failed 2. Wire disconnection between PCB and controller
E 18	High pressure switch fault	1. PCB or controller failed 2. Switch failed
E 19	Low pressure switch fault	1. PCB or controller failed 2. Switch failed
E20	Indoor temperature sensor fault	1. Sensor or sensor wire failed 2. PCB or controller failed
E21	Outdoor temperature sensor fault	Same as E20
E22	External coil temperature sensor fault	Same as E20
E23	Internal heat exchanger temperature sensor fault	Same as E20
E24	Gas suction temperature sensor fault	Same as E20
E25	Gas exhaust temperature sensor fault	Same as E20
E26	Water inlet temperature sensor fault	Same as E20
E27	Water outlet temperature sensor fault	Same as E20
E28	Water temperature sensor fault in the water tank	Same as E20
E30	IPM over curent	1. Driver board failed 2. system failed
E31	Compressor driver fault	
E32	Compressor over current	
E34	Compressor phase current fault	
E35	Radiator overheat to stop machine	
E37	DC bus over voltage	
E38	DC bus under voltage	
E39	AC input under voltage	
E40	AC input over current	
E41	Input voltage fault	
E42	Communication fault between DSP driver and filter board	
E43	Radiator sensor fault	
E44	Communication fault inside the DSP driver	
E45	Communication fault between driver and main PCB	

- 1) The machine stops running when fault is detected;
- 2) When the fault is removed, the compressor is shut down for three minutes before the machine can be put back into operation;
- 3) If there are three consecutive low pressure fault, high pressure fault, over-current fault, and gas exhaust temperature too high within 30 minutes, the machine will immediately stop running. After the fault is rectified, turn the power on again, start the controller, and the machine can be put into operation;
- 4) If the machine stops running due to the inlet water temperature sensor or the coil temperature sensor fault, due to compressor protection, the machine will have to be back into operation 3mins later after the fault is removed. If the ambient temperature sensor fails, the machine continues to run.

Technical Specification

Outdoor unit

Model No.	BLN-012TA1S
Water Proof Level	IPX4
Power Supply	220V/1/50Hz
Heating Capacity at Air 7°C/6°C, Water 35°C out	
Heating Capacity (kW)	10.2KW
Power Input (kW)	2.55KW
COP	3.96
Heating Capacity at Air -12°C/-14°C, Water 35°C out	
Heating Capacity (kW)	7.8KW
Power Input (kW)	3.0KW
COP	2.6
Heating Capacity at Air -20°C/-24°C, Water 41°C out	
Heating Capacity (kW)	6.5KW
Power Input (kW)	3.3KW
COP	1.97
Cooling Capacity at Air 35°C/24°C, Water 12°C in, 7°C out	
Cooling Capacity(kW)	7.5
Power Input(kW)	2.77
EER	2.71
Max Power Input(kW)	5.5
Max Current(A)	24.0
Refrigerant	R410A/2300g
Net Weight(kg)	125
Unpacked Dimensions(L*W*H)(mm)	1005×370×800
Packed Dimensions(L*W*H)(mm)	1100*460*1160
Working temperature range(°C)	-25~43

Indoor Unit

Water Proof Level	IPX0
Power Supply	220V/1/50Hz
Max Power Input(KW)	0.15
Circulation pump power input(KW)	0.15
Circulation pump current input(A)	0.70
Noise (dBA)	35
Net Weight(kg)	49
Unpacked Dimensions(L*W*H)(mm)	465*245*750
Packed Dimensions(L*W*H)(mm)	515*320*880
Water Pressure Drop(kpa)	50
Water Connection(mm)	1-1/4" male
Refrigerant Connection Valve	1/2" 3/4"
Water Flow Volume(m ³ /h)	2.5
Rate water working pressure (MPa)	0.3
Max heat exchanger working pressure (MPa)	4.4
Max gas suction/exhaust pressure (MPa)	4.4/2.7

Packing List		
NO.	Description	Qty
1	Heat pump	1 pc
2	Hydraulic module	1 pc
3	Controller wire	1 pc
4	Instruction manual	1 pc
5	Anti-vibration rubber	1 pc
6	Refrigerant connection pipe	1 pc

- Our company reserves the right to change products and specifications.
- Our company reserves the right to make corrections at any time if there are any printing errors or omissions.

